

## High Productivity Cooking Easyline Electric Boiling Pan with Auto Filling System 60lt

ITEM # \_\_\_\_\_

MODEL # \_\_\_\_\_

NAME # \_\_\_\_\_

SIS # \_\_\_\_\_

AIA # \_\_\_\_\_

**232187 (EBE60AWF)**

 Electric Boiling Pan, with  
 auto filling system, 60lt

### Short Form Specification

**Item No.** \_\_\_\_\_

Stainless steel construction with the deep drawn pan with rounded edges manufactured from AISI 304 stainless steel. Pan can be tilted beyond 90° to completely empty the food. Motorised tilting with tilting axis located in the middle of the pan to keep the pouring lip high and allow tall vessels to be filled. Automatic water filling of the steam generator.

Electric heating elements submerged directly in the water of the jacket. Food is uniformly heated via the base and the side walls of the pan by an indirect heating system using integrally generated saturated steam at a temperature of 112°C in a jacket with an automatic deaeration system. Safety valve avoids overpressure of the steam in the jacket. Safety thermostat protects against low water level. Max pressure at 0,5 bar.

High thermal input and fast heat up. Electromechanical control. Lower temperature outside the panels. IPX5 water protection. For freestanding installation one left column is necessary for each unit.

### Main Features

- Food is uniformly heated in the base and side walls of the kettle by an indirect heating system that uses integrally generated saturated steam at a temperature of 108° C in the jacket with an automatic deaeration system.
- High thermal input and fast heat up.
- Automatic water filling of the double jacket.
- Ergonomic vessel dimensions, with a large diameter and shallow depth facilitates stirring and gentle food handling.
- Curved pan base guarantees that the appliance is also suitable to prepare small quantities of food.
- Safety thermostat protects against low water level.
- Safety valve avoids overpressure of the steam in the jacket.
- Compliant to CE requirements for safety.
- Constructed to meet the highest hygiene standards.
- Safe thanks to the higher water protection IPX5 and the lower temperature outside the panels.
- Fast working thanks to the high efficient heating technology and well insulation that keeps the heat inside the well.

### Construction

- AISI 304 stainless steel construction, including deep drawn pan with rounded edges.
- AISI 304 stainless steel construction with AISI 304L stainless steel deep drawn pan with rounded edges.
- Vessel can be tilted beyond 90° to completely empty the food.
- Motorised tilting.
- Electromechanical control.
- Ergonomic and user friendly thanks to the high tilting position and the pouring lip design which allow to easily fill containers.
- Tilting axis located in the middle of the pan keeps the pouring lip high and allow tall vessels to be filled.
- Electric heating elements are submerged directly in the water of the jacket, the heat losses are very low and the efficiency of the pan accordingly high.
- Max pressure at 0,5 bar, working pressure 0,4 bar.

### Sustainability



- High-quality thermal insulation of the pan saves energy and keeps operating ambient temperature low.

**APPROVAL:** \_\_\_\_\_

**Optional Accessories**

- Left leg/column (to be ordered always one unit for single or multiple installation) PNC 928000
- Floor fastening kit (fastening is integrated in the floor - for a correct installation you need 1 for each pan plus 1 for the left column) PNC 928001
- Kit for a correct and easy positioning and installation of the pan (for a correct installation you need 1 for each pan) PNC 928002
- Floor fastening kit (fastening on the floor surface) PNC 928003
- Measure stick 60lt PNC 928006
- Strainer 8mm holes 60lt PNC 928010
- Bottom grid 60lt PNC 928014
- Basket 60lt, 2 required per pan PNC 928018
- Lifting hook, 2 required PNC 928021

Front

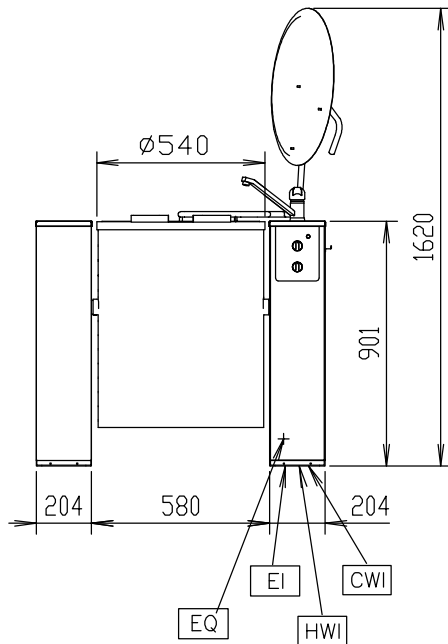

Side

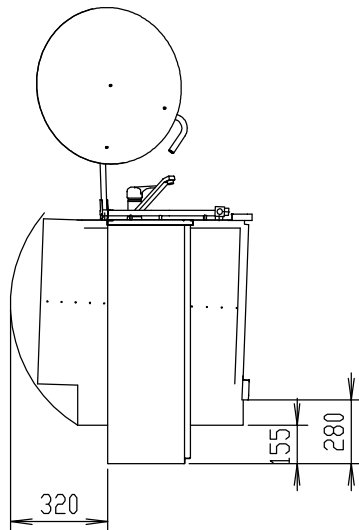

CWI = Cold Water inlet 1  
 (cleaning)  
 D = Drain  
 EI = Electrical inlet (power)

HWI = Hot water inlet

Top

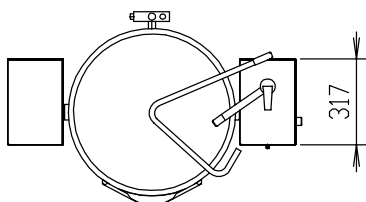

## Electric

Supply voltage:

232187 (EBE60AWF) 400 V/3N ph/50-60 Hz

Electrical power max.:

12 kW

## Key Information:

Working Temperature MIN: 30 °C

Working Temperature MAX: 108 °C

External dimensions, Depth: 700 mm

External dimensions, Height: 900 mm

Net vessel useful capacity: 60 lt

Tilting mechanism: Automatic

Bearing: Central